



**COOLING SYSTEM VACUUM PURGE
& REFILL KIT
CT3570**



INSTRUCTIONS

SAFETY WARNING AND PRECAUTIONS

General Safety Warnings:

 **WARNING:** The instructions and warnings contained in this manual should be read and understood before using or operating this tool. Do not allow anyone to use or operate this tool until they have read this manual and have developed a thorough understanding of how this tool works. Failure to observe any of the following instructions could result in severe personal injury to tool user and bystanders, or cause damage to the tool and property. Keep this manual for future reference.





Note: The warnings and cautions discussed in this instruction manual cannot cover all possible conditions and situations that may occur. It must be understood by the operator that common sense and caution are factors which cannot be built into this product, but must be supplied by the operator.

 **WARNING:** Use safety equipment. User and bystanders should use safety goggles or safety glasses with side shields which comply with current national standards, or when needed, a face shield. Use an ANSI approved dust mask or respirator when working around metal, wood, and chemical dusts and mists. This applies to all persons in the work area. Also use non-skid safety shoes, hardhat, gloves, dust collection systems, and hearing protection when appropriate.

 **WARNING:** Keep bystanders and children out of the work area while operating this tool.

 **WARNING:** Always keep your work area clean, uncluttered, and well lit. Cluttered or dark areas invite accidents and injuries. DO NOT work on floor surfaces that are slippery.

 **WARNING:** Do not operate this tool if you are tired or under the influence of alcohol, drugs, or medications that could affect your ability to use the tool properly.

 **WARNING:** Dress properly. Do not wear loose clothing or jewelry as they can be caught in moving parts. Wear restrictive hair covering to contain long hair.

 **WARNING:** Do not reach over or across running machines. Keep proper footing and balance at all times. Non-skid footwear is recommended when working.

OPERATING INSTRUCTIONS:

To Test For Leaks In Original Radiator Cap

1. Refer to the vehicle's service manual for any specific radiator cap pressure testing instructions.
2. Loosen the vehicle's radiator cap slowly to relieve any excess pressure before removing the cap completely. **NEVER OPEN THE SYSTEM WHILE HOT**, as this may cause personal injury.
3. Choose the correct radiator cap connector (5A or 5B) and correct steel radiator cap (#02, #03, or #04) for the correct vehicle being tested from the test kit. Fasten the original radiator cap to the radiator cap connector (5A or 5B) and then fasten the steel radiator cap (#02, #03, or #04) from the test kit to the other end of the radiator cap connector(5A or 5B).
4. Remove the hand pump assembly (#1) from the test kit and fasten the quick coupler at the end of the hose to the radiator cap (#02, #03, or #04) securely. Operate the hand pump until reaching the pressure recommended by the vehicle manufacturer. - **DO NOT OVER PRESSURIZE THE RADIATOR CAP** . Ideal readings should range between **15-20PSI (1.03-1.37BAR)**.

5. Check the pressure reading on the gauge immediately after reaching the vehicle manufacturer's recommended pressure. If the pressure drops, there is a leak in the radiator cap. After pressure testing is completed, press the release button on the quick coupler until the reading on the gauge reads 0. Remove quick coupler from radiator cap and then remove the original radiator cap from the original radiator cap connector. Discard original radiator cap and replace with new cap if leaking or if it does not meet vehicle manufacturer's recommendations.



PURGING AND REFILLING COOLING SYSTEM:

PURGE COOLING SYSTEM:

1. Drain coolant from radiator.
2. Remove the purge and refill tool (#22) from the test kit and hang the tool in a convenient location under the hood with the hook provided.
3. Choose the correct radiator cap for the vehicle being tested, or the universal rubber radiator adapter (#23) from the test kit and install the one of your choice on the cooling system opening. Fasten the quick coupler at the end of the hose on the purge and refill tool to the radiator cap securely.
4. Turn valve (#27) to the open position and valve (#26) to the closed position.
5. Connect air supply to the purge and refill tool (#22) and press operating button until the pressure reaches 20-25 Hg (50-60cmHg). Turn valve (#27) to the closed position and press ON/OFF SWITCH (#28) off.

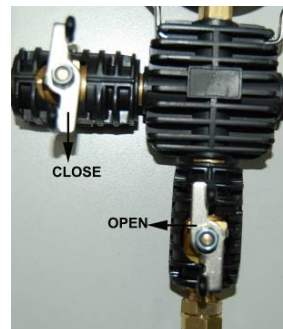
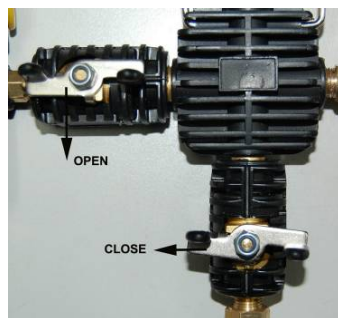

REFILL COOLING SYSTEM:

1. Connect the coolant hose (#24A) to the coolant hose quick coupler (#29) and submerge in coolant.
2. Assure that valve (#27) is in the closed position and that there is coolant in the coolant hose.
3. Turn valve (#26) to the open position to allow the coolant to refill the cooling system.
4. The refill is complete when the gauge reads 0.

Note: Please check the coolant level and add coolant as necessary to the proper level.

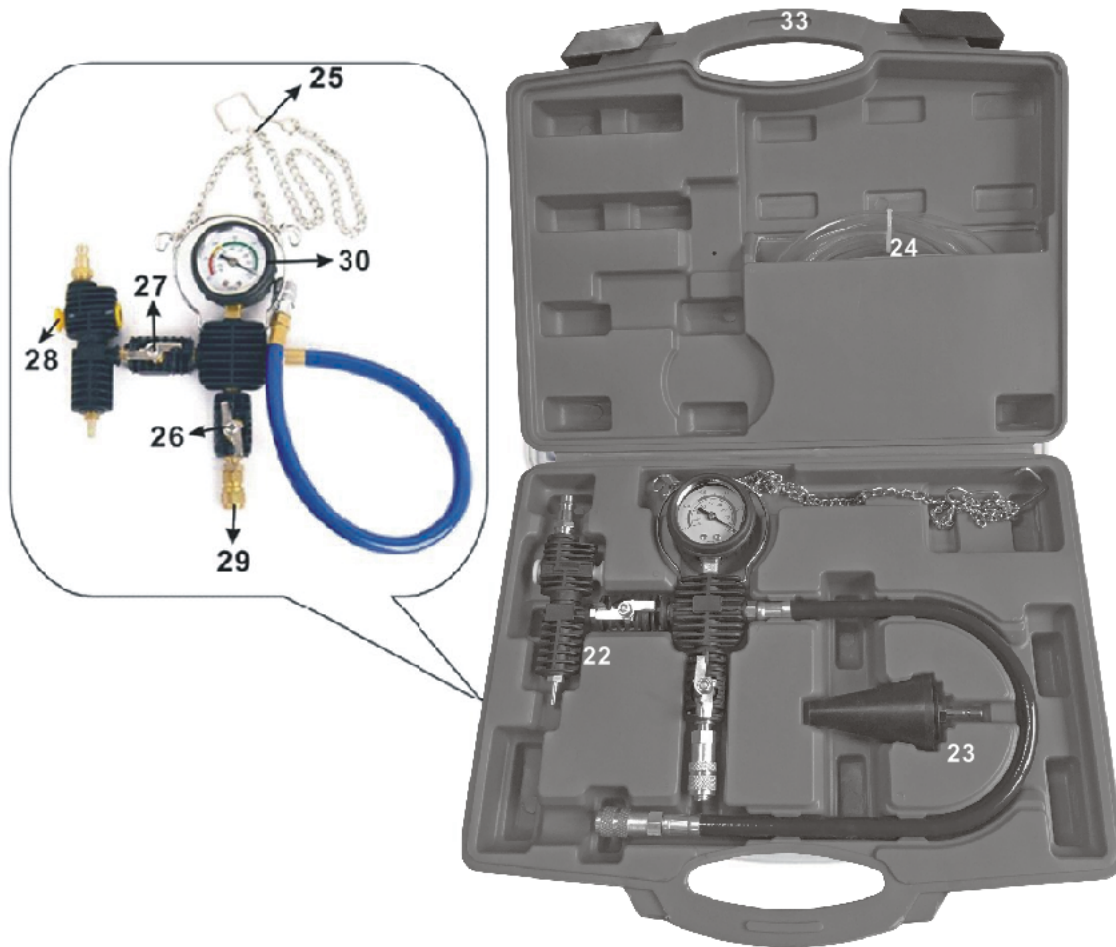

| ITEM# | PART DESCRIPTION |
|-------|-----------------------------------|
| 22 | VACUUM TYPE PURGE AND REFILL TOOL |
| 23 | UNIVERSAL RUBBER RADIATOR ADAPTOR |
| 24 | COOLANT HOSE WITH ADAPTER |
| 25 | HOOK |
| 26 | VALVE SWITCH |
| 27 | VALVE SWITCH |
| 28 | ON/OFF SWITCH |
| 29 | COOLANT HOSE QUICK COUPLER |
| 30 | GAUGE, PU HOSE AND TOOL MAIN BODY |
| 33 | BLOW MOLD CASE |